AMERICAN NATIONAL STANDARD/AMERICAN DENTAL
ASSOCIATION STANDARD NO. 41

**Evaluation of biocompatibility of medical
devices used in dentistry**

Modified adoption of ISO 7405:2008 Dentistry — Evaluation
of biocompatibility of medical devices used in dentistry

Contents

Page

Foreword	iv
Introduction.....	v
1 Scope	1
2 Normative references	1
3 Terms and definitions	2
4 Categorization of medical devices	3
4.1 Categorization by nature of contact	3
4.2 Categorization by duration of contact.....	3
5 Biological evaluation process.....	4
5.1 General	4
5.2 Selection of tests and overall assessment	4
5.3 Selection of test methods.....	4
5.4 Types of test	5
5.5 Re-evaluation of biocompatibility.....	6
6 Test procedures specific to dental materials	6
6.1 Recommendations for sample preparation	6
6.2 Agar diffusion test.....	8
6.3 Filter diffusion test	10
6.4 Pulp and dentin usage test.....	13
6.5 Pulp capping test.....	18
6.6 Endodontic usage test.....	20
Annex A (informative) Types of test to be considered for evaluation of biocompatibility of medical devices used in dentistry.....	24
Annex B (informative) Dentin barrier cytotoxicity test.....	26
Annex C (informative) Acute toxicity testing	33
Bibliography.....	34

Foreword

(This Foreword does not form a part of the Revised ANSI/ADA Standard No. 41 for Evaluation of biocompatibility of medical devices used in dentistry).

This Standard is a revision of ANSI/ADA Standard No. 41, which was approved in 2005,. This revision was prepared by the ADA Standards Committee on Dental Products (SCDP) Joint Working Group 1.

The objective of this Standard is to provide detailed guidelines and methodologies for evaluating the biocompatibility of dental materials following International Standard ISO 7405, Dentistry - biocompatibility of medical devices used in dentistry. ANSI/ADA Standard No. 41 is intended to be a modification of ISO 7405 for the benefit of United States dental professionals, scientists, and manufacturers. The intent of this Standard is to provide a framework through which regulatory approval can be obtained for dental products in the U. S. as well as in other countries that recognize ISO standards.

Introduction

This standard concerns the evaluation of the biocompatibility of medical devices used in dentistry. It is to be used in conjunction with the ISO 10993 series of standards. This standard contains special tests, for which ample experience exists in dentistry and which acknowledge the special needs of dentistry.

Only test methods for which the members of the committee considered there was sufficient published data have been included. In recommending test methods, the need to minimize the use of animals was given a high priority. It is essential that the decision to undertake tests involving animals be reached only after a full and careful review of the evidence indicating that a similar outcome cannot be achieved by other types of test. In order to keep the number of animals required for tests to an absolute minimum, consistent with achieving the objective indicated, it can be appropriate to conduct more than one type of test on the same animal at the same time, e.g. pulp and dentin usage test and pulp capping test. However, in accordance with ISO 10993-2 these tests are performed both in an efficient and humane way. On all occasions when animal testing is undertaken, such tests are conducted empathetically and according to standardized procedures as described for each test.

This standard does not explicitly describe test methods for occupationally related risks.

Annexes B and C are included to encourage the development of *in vitro* and *ex vivo* test methods which will further reduce the use of animals in the evaluation of the biocompatibility of medical devices used in dentistry.

Dentistry — Evaluation of biocompatibility of medical devices used in dentistry

1 Scope

This standard covers standard practices for the biological evaluation of the safety of medical devices used in dentistry. In addition, this document covers biological evaluation of the device component of combination products, including those with a pharmacological agent or biologic component as an integral part of the device.

This standard does not cover testing of materials and devices that do not come into direct or indirect contact with the patient's body.

2 Normative references

The following referenced documents are indispensable for the application of this document. For dated references, only the edition cited applies. For undated references, the latest edition of the referenced document (including any amendments) applies.

ISO 1942, *Dentistry — Vocabulary*

ISO 6344-1, *Coated abrasives — Grain size analysis — Part 1: Grain size distribution test*

ISO 10993-1, *Biological evaluation of medical devices — Part 1: Evaluation and testing within a risk management process*

ISO 10993-2, *Biological evaluation of medical devices — Part 2: Animal welfare requirements*

ISO 10993-3, *Biological evaluation of medical devices — Part 3: Tests for genotoxicity, carcinogenicity and reproductive toxicity*

ISO 10993-5, *Biological evaluation of medical devices — Part 5: Tests for in vitro cytotoxicity*

ISO 10993-6, *Biological evaluation of medical devices — Part 6: Tests for local effects after implantation*

ISO 10993-10¹⁾, *Biological evaluation of medical devices — Part 10: Tests for irritation and skin sensitization*

ISO 10993-11, *Biological evaluation of medical devices — Part 11: Tests for systemic toxicity*

ISO 10993-12:2007, *Biological evaluation of medical devices — Part 12: Sample preparation and reference materials*

ISO 10993-17, *Biological evaluation of medical devices—Part 17: Establishment of allowable limits for leachable substances*

ISO 10993-18, *Biological evaluation of medical devices— Part 18: Chemical characterization of materials*

ISO 14971, *Medical devices — Application of risk management to medical devices*

1) To be published.

3 Terms and definitions

For the purposes of this document, the terms and definitions given in ISO 1942, ISO 10993-1, ISO 10993-12 and the following apply.

3.1

medical device

any instrument, apparatus, appliance, software, material or other article, whether used alone or in combination, together with any accessories, including the software necessary for its proper application intended by the manufacturer to be used for medical purposes for human beings for the purpose of:

- diagnosis, prevention, monitoring, treatment or alleviation of disease;
- diagnosis, monitoring, treatment, alleviation of or compensation for an injury or handicap;
- investigation, replacement or modification of the anatomy or of a physiological process;
- control of conception;

and which does not achieve its principal intended action in or on the human body by pharmacological, immunological or metabolic means, but which may be assisted in its function by such means

3.2

dental material

material and/or substance or combination of materials and/or substances specially formulated and prepared for use in the practice of dentistry and/or associated procedures

3.3

final product

medical device in its “as-used” state

NOTE Many dental materials are used in a freshly mixed state, and evaluation of the materials in both freshly mixed and set conditions should be considered.

3.4

negative control

negative control material

any well characterized material and/or substance that, when evaluated by a specific test method, demonstrates the suitability of the test system to yield a reproducible, appropriately negative, non-reactive or minimal response in the test system

NOTE In practice, negative controls include blanks, vehicles/solvents and reference materials.

3.5

positive control

positive control material

any well characterized material and/or substance that, when evaluated by a specific test method, demonstrates the suitability of the test system to yield a reproducible, appropriately positive or reactive response in the test system

3.6

reference material

material with one or more property values that are sufficiently reproducible and well established to enable use of the material or substance for the calibration of an apparatus, the assessment of a measurement method or for the assignment of values to materials

NOTE For the purpose of this document, a reference material is any well characterized material and/or substance that, when tested by the procedure described, demonstrates the suitability of the procedure to yield a reproducible, predictable response. The response may be negative or positive.

4 Categorization of medical devices

4.1 Categorization by nature of contact

4.1.1 General

For purposes of this document, the classification of medical devices used in dentistry is derived from ISO 10993-1. If a device or material can be placed in more than one category, the more rigorous testing requirements shall apply. With multiple exposures the decision into which category a device is placed shall take into account the potential cumulative effect, bearing in mind the period of time over which these exposures occur.

NOTE In this context the term dentistry includes the oromaxillofacial environment.

4.1.2 Non-contact devices

These devices do not contact a person's body directly or indirectly, and are not included in ISO 10993-1.

4.1.3 Surface-contacting devices

These devices include those that contact the surface of intact or breached skin, the surface of intact or breached oral mucosa, and those that contact the external surfaces of dental hard tissue, including enamel, dentin and cementum. Dentin and cementum are considered as surfaces; e.g., after gingival recession.

4.1.4 External communicating devices

These devices include dental devices that penetrate and are in contact with oral mucosa, dental hard tissues, dental pulp tissue or bone, or any combination of these, and are exposed to the oral environment.

NOTE This group also includes any kind of lining or base material to be used under a restoration.

4.1.5 Implant devices used in dentistry

These devices include dental implants and other dental devices that are partially or fully embedded in one or more of the following:

- a. soft tissue, e.g. subperiosteal implants and subdermal implants;
- b. bone, e.g. endosteal implants and bone substitutes;
- c. pulpodental system of the tooth, e.g. endodontic materials;
- d. any combination of these, e.g. transosteal implants.

4.2 Categorization by duration of contact

4.2.1 General

For purposes of this document, medical devices used in dentistry are classified by duration of contact as described in ISO 10993-1 and listed in 4.2.2 to 4.2.4.

4.2.2 Limited exposure devices

Devices for which single or multiple use or contact is likely to be up to 24 h.

4.2.3 Prolonged exposure devices

Devices for which single, multiple or long-term use or contact is likely to exceed 24 h but not 30 d.

4.2.4 Permanent contact devices

Devices for which single, multiple or long-term use or contact exceeds 30 d.

NOTE 1 The definition of the term “permanent” is meant to be applied solely for the use of this document. It is consistent with the definition given in ISO 10993-1.

NOTE 2 With multiple exposures to the device, the decision into which category a device is placed should take into account the potential cumulative effect, bearing in mind the period of time over which these exposures occur.

5 Biological evaluation process

5.1 General

Each medical device used in dentistry shall be subjected to a structured biological evaluation program within a risk management process (see ISO 10993-1). Guidance on the implementation of this program is provided in ISO 14971 and ISO 10993-1. The biological evaluation program shall include the review of data sets concerning the biological properties of each medical device used in dentistry. When this part of the biological evaluation program indicates that one or more data sets are incomplete and that further testing is necessary, the tests should be selected from the methods described in the ISO 10993 series of standards or in this standard, or in both. If tests that are not included in these standards are selected, a statement shall be made that indicates that the tests described in these standards have been considered and shall include a justification for the selection of other tests.

For combination products the final product should be evaluated according to this document in conjunction with any applicable standards.

NOTE 1 In this context, combination products are dental devices of any kind that incorporate, or are intended to incorporate, as an integral part, a substance that:

- a. if used separately, would be a medicine or a biological product;
- b. is liable to affect the patient’s body by an ancillary action.

An example would be a bone filling/augmentation device containing a growth factor (i.e. a biological product).

It is strongly recommended that laboratory and animal studies be conducted in compliance with Good Laboratory Practice (GLP) regulations (Title 21, Code of Federal Regulations, Part 58).

NOTE 2 For combination products, where the device and pharmacological components are packaged separately, it may be informative to test the device components alone.

5.2 Selection of tests and overall assessment

The selection of tests and the overall assessment of the results shall be carried out by an expert who has the appropriate chemical, physical and biological data concerning the device and who is aware of the intended conditions of use.

5.3 Selection of test methods

The selection of test methods shall be based upon consideration of:

- a. the intended use of the medical device;
the tissue(s) which the medical device may contact;
- b. the duration of the contact.

If a test selected is not included in the ISO Standards, a justification for the choice of the methods shall be included in the test report for each device. If more than one test method in the same category is recommended by the standards, the selection of one test over the others should be justified.

5.4 Types of test

According to the categorization of the device, tests shall be considered for use as summarized in Table A.1. This table indicates which types of test method shall be considered, but not that they are necessarily required to be carried out. A decision not to carry out a type of test identified in Table A.1 shall be justified in the test report on each device. The types of test listed are regarded as a framework for the evaluation of the biocompatibility of medical devices used in dentistry. For most types of test, particular methods are identified, although for some devices it is recognized that alternative methods not included in the International Standards listed may be more appropriate. Confirmation of the suitability of a testing strategy from the U. S. Food and Drug Administration should be considered before beginning product testing.

For convenience, the types of test have been listed in three groups.

c. Group I

This group comprises *in vitro* tests of cytotoxicity. General guidance for *in vitro* cytotoxicity tests is presented in ISO 10993-5 and shall be followed. Detailed test protocols for the agar or agarose diffusion and filter diffusion methods, appropriate to dental materials, are included in this International Standard. The *in vitro* cytotoxicity methods include:

- 1) agar diffusion test (see 6.2);
- 2) filter diffusion test (see 6.3);
- 3) direct contact or extract tests in accordance with ISO 10993-5;
- 4) dentin barrier cytotoxicity test (see Annex B);
- 5) tooth slice model.

NOTE 1 The order of listing does not indicate any preference for one method over another.

NOTE 2 This list does not indicate that all cytotoxicity tests mentioned have to be performed for each medical device under consideration.

NOTE 3 The use of the dentin barrier cytotoxicity test is encouraged and a description of the test is presented in Annex B. Another approach is the tooth slice model. References to this test are presented in the Bibliography.

Group II

This group comprises tests in accordance with the ISO 10993 series of standards and particular tests, where appropriate, are identified:

- 6) acute systemic toxicity — oral application — in accordance with ISO 10993-11;
- 7) acute systemic toxicity — application by inhalation — in accordance with ISO 10993-11;
- 8) subacute and subchronic systemic toxicity — oral application — in accordance with ISO 10993-11;
- 9) skin irritation and intracutaneous reactivity in accordance with ISO 10993-10;
- 10) delayed-type hypersensitivity in accordance with ISO 10993-10;
- 11) genotoxicity in accordance with ISO 10993-3;
- 12) local effects after implantation in accordance with ISO 10993-6.

NOTE 1 In order to allow use of the latest edition of the referenced document only, an undated cross-reference is possible. An indication of the appropriate clause and subclause is only possible for dated references. Therefore, the user of this International Standard is requested to check the referenced documents for the appropriate clause numbers.

NOTE 2 Information regarding acute toxicity testing is presented in Annex C.

NOTE 3 In the evaluation of materials following local implantation involving mineralized tissues in accordance with ISO 10993-6, examination of undemineralized sections, in addition to routine demineralized sections, is recommended.

Group III

This group comprises tests, specific for medical devices used in dentistry, not referred to in the 10993 series of standards:

- 1) pulp and dentine usage test (see 6.4);
- 2) pulp capping test (see 6.5);
- 3) endodontic usage test (see 6.6).

NOTE Dental implant system usage test in accordance with ISO/TS 22911 can also be considered, if applicable.

5.5 Re-evaluation of biocompatibility

In accordance with ISO 10993-1, a device shall be considered for re-evaluation of its biocompatibility as described in 5.4 when revisions or modifications to the formula, quality and/or performance specifications are made.

6 Test procedures specific to dental materials

6.1 Recommendations for sample preparation

6.1.1 General

These recommendations have been designed for *in vitro* testing, but can also be used for other purposes, if suitable.

6.1.2 General recommendations for sample preparation

For the preparation of test samples, consult the respective product standards and/or the manufacturer's instructions, and follow those descriptions as closely as possible. Justify any deviation from the manufacturer's instructions. A detailed description of the sample preparation shall be included in the test report. Take the following (e.g. environmental) factors into account, considering the final use of the device:

- a. **temperature**;
- b. **humidity**;
- c. **light exposure**: samples of photosensitive materials should be produced under the condition that ambient light does not activate them;
- d. **material of sample mold**: ensure that the material of the sample mold and eventual lubricant used do not interfere with the setting process of the material;

NOTE Suitable materials can be semitranslucent or white plastic materials such as polyethylene or polytetrafluoroethylene (PTFE).

oxygen exposure: for materials that produce an oxygen inhibited layer during hardening ensure that the sample mold is properly sealed during hardening;

sterilization: samples should either be produced under aseptic conditions or be sterilized by the method appropriate to the material, if necessary and possible; ensure that sterilization does not affect the material (e.g. sterilization shall not elute substances from material);

ratio of sample surface area versus cell layer surface or cell culture medium: document the ratio of sample surface area versus cell layer surface or cell culture medium; justify the selection of shape and sample surface area and the applied ratio of sample surface area versus cell layer surface or cell culture medium;

extracts: if extracts are required for a test procedure, prepare extract samples in accordance with ISO 10993-12.

6.1.3 Specific recommendations for light curing materials

Take the following factors into account, considering the final use of the light curing material:

- a. **material of sample mold:** the reflection coefficient of materials used for sample molds should be as close as possible to that of dentin in order to simulate the clinical situation;

NOTE Suitable materials can be semitranslucent or white plastic materials such as polyethylene or PTFE.

light exposure: light curing should be done to simulate clinical usage as closely as possible. The manufacturer's instructions for use should be followed to provide the same level of curing as would be the case in actual usage. This will often require curing from one side only but will sometimes entail a two-sided cure. The cure method is material and/or process specific. Where fully cured test samples are required for testing, it is important to ensure that the test samples are homogeneous after removal from the mold. In the case of one-component materials, there should be no voids, clefts or air-bubbles present when viewed without magnification. Reference should be made to the light source used (light intensity, curing time, spectral distribution of curing light and type of curing light should be documented). Care shall be taken to ensure that the light source is recommended for the materials to be tested and that it is in a satisfactory operating condition;

oxygen exposure: for materials that produce an oxygen inhibited layer during light curing, both ends of the mold should be covered with transparent oxygen barrier materials (e.g. a polyester film) during light curing. If the material is recommended by the manufacturer for surface finishing after curing, the sample surfaces should be ground and polished using the recommended clinical procedures. If there are no such instructions and if required for testing, the samples should be ground on both ends, with a P2 000 paper in accordance with ISO 6344-1, after first being set against the transparent oxygen barrier material.

6.1.4 Specific recommendations for chemically setting materials

Take the following factors into account, considering the final use of the chemically setting materials:

- a. **mixing:** mix sufficient material to ensure that the preparation of each test sample is completed from one batch. Prepare a fresh mix for each test sample. The mixing shall be performed in accordance with the respective product standards, if applicable;

oxygen exposure: for materials that produce an oxygen inhibited layer during chemical curing, both ends of the mold should be covered with oxygen barrier materials (e.g. a polyester film) during curing. If the material is recommended by the manufacturer for surface finishing after curing, the sample surfaces should be ground and polished using the recommended clinical procedures. If there are no such instructions and if required for testing, the samples should be ground on both ends, with a P2 000 paper in accordance with ISO 6344-1, after first being set against the oxygen barrier material.

6.1.5 Positive control material

- a. For both in vitro and in vivo tests, it is advisable to include a standard positive control material that is handled and processed like the test materials (i.e. being plastic after mixing and then setting) and which is based on freely available chemicals or materials. Such a positive control material for in vitro testing of plastic filling materials is described in Annex B, Table B.1. The use of this specific positive control material is

optional and other materials with a validated history and other well characterized positive control materials with reproducible data on toxicity can be used instead.

6.2 Agar diffusion test

6.2.1 Objective

This test is designed to demonstrate the nonspecific cytotoxicity of test materials after diffusion through agar or agarose. This test method is not appropriate for leachables that do not diffuse through agar or agarose.

6.2.2 Cell line

Use an established fibroblast or epithelial cell line, which is readily available [e.g. from the American Type Culture Collection (ATCC), see <http://www.atcc.org>²⁾]. Specify in the report the identification number of the cell line, if applicable, the description and designation of the cell line used and a justification for its selection.

6.2.3 Culture medium, reagents and equipment

Use the culture medium specified for the selected cell line. Sterilize by filtration. For the preparation of the agar, prepare a double-concentration of the culture medium. Sterilize by filtration. Prepare either 3 % agar or 3 % agarose. Sterilize by autoclaving.

Prepare the vital stain by diluting a stock solution of 1 % aqueous neutral red solution (record source) 1:100 with 0.01 mol/l phosphate-buffered saline solutions [e.g. Dulbecco's phosphate-buffered saline solution³⁾] immediately before use. Store neutral red solutions protected from the light. Use 6-well tissue culture plates (35 mm in diameter) or Petri dishes of 50 mm to 100 mm in nominal diameter suitable for tissue culture.

6.2.4 Sample preparation

Prepare the samples in accordance with 6.1. The test shall be performed on either an extract of the material and/or the material itself, according to the guidance in ISO 10993-5.

- a. For solid materials, prepare circular test samples of approximately 5 mm diameter, with a flat surface to ensure adequate contact with the agar overlay.
- b. For setting materials, insert the freshly mixed material into rings of internal diameter 5 mm and height 2 mm. The material of the ring shall be stated in the test report. When testing materials in the freshly mixed state, place the rings on the agar prior to inserting the material. When testing after various setting periods, fill the rings so that the material is flush with the rim and allow it to set at (37 ± 2) °C and a relative humidity of (90 ± 10) % until ready for testing.
- c. For fluid test samples or extracts, imbibe 0.01 ml of the fluid on a borosilicate microglass filter disc of 5 mm diameter, placed on the agar.

NOTE 1 Suitable inert materials are glass or PTFE.

NOTE 2 Suitable discs can be prepared from prefilters.

6.2.5 Controls

Use positive controls, negative controls and reference materials.

2) This information is given for the convenience of users of this standard and does not constitute an endorsement of the product named. Equivalent products may be used if they can be shown to lead to the same results.

3) Dulbecco is a trade name. This information is given for the convenience of users of this standard and does not constitute an endorsement of the product named. Equivalent products may be used if they can be shown to lead to the same results.

6.2.6 Test procedure

Culture the cells until they reach the end of the log growth phase. Pipette the proper volume (e.g. 10 ml for a 100 mm Petri dish) of cell suspension (2.5×10^5 cells/ml) into a sufficient number of Petri dishes and incubate at (37 ± 2) °C in a water-saturated atmosphere with 5% (volume fraction) carbon dioxide for 24 h. If different cell culturing conditions are used, justification shall be provided.

Heat the sterile agar or agarose to 100 °C in a water bath and allow it to cool to 48 °C. Mix one part of agar or agarose with one part of double-concentrated, freshly prepared culture medium and heat to 48 °C. Aspirate the liquid culture medium from each Petri dish and replace with 10 ml of freshly prepared agar or agarose/culture medium mixture.

Allow the agar or agarose/culture medium mixture to solidify at room temperature (approximately 30 min). Add 10 ml neutral red solution and keep dark for 15 min to 20 min. Aspirate excess neutral red solution.

Protect the culture from light in the presence of neutral red, as the cells can be damaged.

Apply to each dish an appropriate number of samples of test material and controls, with an adequate distance (> 20 mm) between adjacent samples, if applicable. Incubate at (37 ± 2) °C in a water-saturated atmosphere with 5 % (volume fraction) carbon dioxide for 24 h. Examine each test material at least in quadruplicate (i.e. two dishes per test material).

6.2.7 Parameters of assessment

Assess the decolorization zone around the test materials and controls using an inverted microscope with a calibrated screen, and determine a decolorization index and a lysis index for each test sample in accordance with the criteria specified in Tables 1 and 2.

Table 1 — Decolorization index

Decolorization index	Description
0	No detectable decolorization zone around or under specimen
1	Decolorization zone limited to area under specimen
2	Decolorization zone extends less than 0,5 cm beyond specimen
3	Decolorization zone extends 0,5 cm to 1,0 cm beyond specimen
4	Decolorization zone extends further than 1,0 cm beyond specimen but does not involve entire dish
5	Decolorization zone involves entire dish

Table 2 — Lysis index

Lysis index	Description of decolorized zone
0	No observable cytotoxicity
1	< 20 % of the decolorized zone affected
2	20 % to < 40 % of the decolorized zone affected
3	40 % to < 60 % of the decolorized zone affected
4	60 % to 80 % of the decolorized zone affected
5	> 80 % of the decolorized zone affected

Calculate the median decolorization index and lysis index separately for each test material. If the index values for the four replicates of the test substance differ by more than 2 units in the range 0 to 3, repeat the test. With indices of 4 and 5, no repetition is necessary. When extracts are tested, subtract the median index of the extraction medium alone from the median index of the extraction medium containing test substance to obtain the index for the test substance alone. If the median index for the extraction medium serving as a control is > 1, repeat the test using a different extraction medium.

NOTE For a valid test, an intact cell layer should be found under the negative control.

6.2.8 Assessment of results

Take into account all information gathered in the test in assessing the test results, particularly any differences in results between the experimental and control groups. The cell response is based on the median decolorization index and lysis index of at least four replicate tests. The cell response shall be graded separately for each parameter, in accordance with Table 3.

Table 3 — Cell response (graded separately for decolorization index and lysis index) and interpretation of cytotoxicity

Scale	Cell response	Interpretation
0	0	Non cytotoxic
1	1	Mildly cytotoxic
2	2 to 3	Moderately cytotoxic
3	4 to 5	Severely cytotoxic

Include the results of the assessment in the test report.

NOTE It should be borne in mind that the interpretation of data from cell culture tests must take the limitations of this test system into account; i.e. a material that is cytotoxic is not per se unsuitable, but the data must be interpreted for each specific application.

6.2.9 Test report

Submit the results in a test report that includes a complete record of all procedures followed, all results obtained and any other data necessary for the assessment of results. Include details of the preparation and methods of application of the test material, together with the lot number of the material when appropriate.

6.3 Filter diffusion test

6.3.1 Objective

This test is designed to demonstrate the nonspecific cytotoxicity of test materials after diffusion through a cellulose acetate filter.

6.3.2 Cell line

Use an established fibroblast or epithelial cell line, which is readily available [e.g. from the American Type Culture Collection (ATCC), see <http://www.atcc.org>]. Specify in the report the identification number of the cell line, if applicable, the description and designation of the cell line used, and a justification for its selection.

6.3.3 Culture medium, reagents and equipment

Prepare culture medium and agar or agarose for use as an overlay as described in 6.2.3. Prepare solutions either for succinate dehydrogenase staining or for nonspecific hydrolase staining.

For succinate dehydrogenase staining, prepare the following stock solutions:

- a. **succinate solution**, 13.6 g sodium succinate in 100 ml of 0.2 mol/l phosphate buffer, pH 7.6;
- b. **nitro blue tetrazolium chloride solution**, 100 mg nitro blue tetrazolium chloride in 100 ml of 0.2 mol/l phosphate buffer, pH 7.6;
- c. **phenazine methosulfate solution**, 4 mg phenazine methosulfate in 10 ml fresh distilled water.

Prepare a staining solution of 1 ml succinate solution, 9 ml nitro blue tetrazolium chloride solution and 1 ml phenazine methosulfate solution.

For nonspecific hydrolase staining, prepare a stock solution of fluorescein diacetate consisting of 5 mg fluorescein diacetate in 1 ml acetone. For use, add 20 µl of stock solution to 100 ml phosphate-buffered saline solution (e.g. Dulbecco's phosphate-buffered saline solution). Use Petri dishes of 60 mm nominal diameter, suitable for tissue culture.

Use filters, composed of a mixture of cellulose acetate and cellulose nitrate, 47 mm diameter, 0.45 µm pore size⁴⁾.

6.3.4 Sample preparation

Prepare the samples in accordance with 6.1. The test shall be performed on either an extract of the material or the material itself, according to the guidance in ISO 10993-5.

- a. For solid materials, prepare circular test samples of approximately 5 mm diameter, with a flat surface to ensure adequate contact with the filter. The mass of the test samples shall not exceed 3.5 g.
- b. For setting materials, insert the freshly mixed material into rings of internal diameter 5 mm and height 2 mm. When testing materials in the freshly mixed state, place the rings on the filter prior to inserting the material. When testing after various setting periods, fill the rings so that the material is flush with the rim and allow it to set at (37 ± 2) °C and a relative humidity of (90 ± 10) % until ready for testing. The mass of the test samples shall not exceed 3.5 g.

NOTE Suitable inert materials can be glass or PTFE.

For fluid test samples or extracts, imbibe 0.01 ml of the fluid on a borosilicate microglass filter disc of 5 mm diameter, placed on the agar.

NOTE Suitable discs can be prepared from prefilters.

6.3.5 Controls

Use positive controls, negative controls and reference materials.

6.3.6 Test procedure

Culture the cells until they reach the end of the log growth phase. Place cellulose acetate filters in the bottom of a sufficient number of Petri dishes and pipette 6 ml of cell suspension (2.5×10^5 cells/ml) into each. Incubate at (37 ± 2) °C in a water-saturated atmosphere with 5 % (volume fraction) carbon dioxide for 24 h. If different cell culturing conditions are used, justification shall be provided. Pipette 5 ml of freshly prepared agar or agarose/culture medium mixture (see 6.2.6) kept at 48 °C into a sufficient number of Petri dishes and allow it to solidify at room temperature. Aspirate the excess culture medium from the dishes containing cellulose acetate filters, wash the filters with phosphate-buffered saline solution (e.g. Dulbecco's phosphate-buffered saline solution) at (37 ± 2) °C and place them on top of the agar or agarose, cell side down. Apply three to five test samples on top of the filter in each dish and incubate for a further 2 h and 24 h at (37 ± 2) °C in a water-saturated

4) Millipore HATF 04700 is an example of a suitable product available commercially. This information is given for the convenience of users of this International Standard and does not constitute an endorsement of the product named. Equivalent products may be used if they can be shown to lead to the same results.

atmosphere with 5 % (volume fraction) carbon dioxide. Ensure that the test samples are in close contact with the surface of the filter. Evidence of cytotoxicity shall be evaluated after exposure periods of 2 h and of 24 h. In each dish, include one positive control and one negative control. In addition, use further controls of a filter with a cell monolayer but without test samples, and of a filter without cells but with test samples. When extracts are tested, a control using the extraction medium alone shall also be used. Examine each test sample at least in quadruplicate.

After incubation, remove the test samples and gently loosen the filter from the agar or agarose. Assess cytochemically the area of reduced cell enzyme activity by Method A or Method B.

a. Method A

Demonstrate succinate dehydrogenase (EC 1.3.99.1) according to the method of Barka and Anderson [14]. The incubation period is 3 h at (37 ± 2) °C. Wash the filter in distilled water and air-dry prior to measurement.

NOTE Cell retention can be aided by fixing the cells with 10 % neutral formalin for 15 min prior to washing in distilled water.

Method B

Demonstrate nonspecific hydrolase by incubation with fluorescein diacetate solution for 30 min at 4 °C. Examine the filter under ultraviolet light.

6.3.7 Assessment of cell damage

Assess cell damage by either

- a. measuring the area of decolorization (e.g. by means of an image analysis system) or
- b. using the scale defined in Table 4.

Table 4 — Assessment of cell damage

Scale	Grading assessment	Area of decolorization
0	No difference in staining intensity across the filter	None
1	A zone of reduced staining intensity, or an unstained zone with a diameter less than that (5 mm) of the test sample	<20 mm ²
2	An unstained zone 5 mm to 7 mm in diameter	20 mm ² to 40 mm ²
3	An unstained zone greater than 7 mm in diameter	>40 mm ²

NOTE The filters beneath the negative controls and the control filters should be uniformly stained dark blue (if succinate dehydrogenase is used) or light green (if nonspecific hydrolase is used). The control filters without cells allow determination of a possible effect of the test sample on the filter.

6.3.8 Assessment of results

All information gathered in the test shall be taken into account in assessing the test results, particularly any differences in results between the experimental and control groups. A useful way to grade test materials is presented in Table 5.

Table 5 — Grading of test material

Cell damage index	Description of decolorized zone
0	Non cytotoxic
1	Mildly cytotoxic

2	Moderately cytotoxic
3	Severely cytotoxic

Include the results of the assessment in the test report.

NOTE It should be borne in mind that the interpretation of data from cell culture tests must take the limitations of this test system into account; i.e. a material which is cytotoxic is not per se unsuitable, but the data must be interpreted for each specific application.

6.3.9 Test report

Submit the results in a test report, which includes a complete record of all procedures followed, all results obtained and any other data necessary for the assessment of results. Include details of the preparation and methods of application of the test material, together with the lot number of the material when appropriate.

6.4 Pulp and dentin usage test

6.4.1 Objective

The test is designed to assess the biocompatibility of dental materials with the dental pulp. Procedures necessary for the proposed clinical use of a material are included in the assessment. The same format may be used for human teeth (scheduled for extraction for orthodontic, periodontic or prosthodontic reasons) provided the study has been appropriately approved. It should be stressed that the pulp and dentin usage test is not only a biocompatibility (toxicity) test but a clinical usage test as well.

6.4.2 Animals and animal welfare

For animal welfare comply with either

- a. ISO 10993-2 or
- b. national regulatory requirements for laboratory animals.

NOTE 1 The animals should be housed according to ISO 10993-2 and have free access to food and water.

Use non-rodent mammals of one species of such an age that their dentition contains intact permanent teeth with closed mature apices and no more than superficial attrition.

Monkeys, dogs, ferrets or miniature pigs are suitable species. Other species may be suitable for special purposes. The species selected should be the lowest required to satisfy the scientific objective at the lowest animal welfare cost. The choice of species shall be justified and documented.

NOTE 2 Suitable monkeys, dogs and miniature pigs are those in which all the permanent teeth, other than M3, have erupted. Suitable ferrets are those in which the four permanent canines have erupted, as only those teeth are suitable.

6.4.3 Test procedure

6.4.3.1 Preparation of animals

Select sufficient animals to provide at least seven teeth containing test material for each time period.

Anaesthetize the animals and carry out the procedure described in 6.4.3.2.

6.4.3.2 Treatment of teeth

6.4.3.2.1 Remove all calculus and debris from the tooth surfaces. Clean and disinfect the surfaces of the teeth to be used by swabbing with 3 % (volume fraction) hydrogen peroxide followed by a disinfectant consisting

of povidone-iodine or chlorhexidine. Prepare the required number of Class V buccal or labial cavities using sharp burs under an adequate air-water spray. Prepare all cavities to a depth such that their remaining dentin thickness is less than 1.0 mm but more than 0.5 mm. Rinse the cavities with water and dry them with cotton pellets or an oil free compressed air, unless the method of insertion of the test material requires a different procedure.

NOTE 1 If animals have marked gingival inflammation, it may be necessary to carry out a calculus and debris removal a few days before cavity preparation, and even repeatedly until gingival inflammation is controlled.

NOTE 2 Electrical impedance measuring instruments, such as root apex locators, can be pre-calibrated and used to help estimate the remaining dentin thickness during cavity preparation.

6.4.3.2.2

If a product or material is to be used as a luting agent, Class V cavity inlay preparations should be made. In order to simulate hydraulic pressure during crown cementation Class V composite resin inlays need to be fabricated. Artificial saliva can be used as a lubricant in the cavity preparation followed by insertion of a light curing resin composite. After light curing and removal of the resin composite inlay the cavity needs to be thoroughly rinsed and prepared to receive the inlay for final cementation. (Note: Overfilling of the inlay preparation facilitates inlay removal and the excess can be cut back after cementation following hardening of the luting agent. A fine diamond high speed bur and light pressure with copious water cooling is recommended to prevent unwanted disruption of the integrity of the cement.) The inlays should be held under pressure for the length of time necessary for the initial set of the cement to occur, thus simulating the hydraulic forces of full crown cementation. In small animals, ensure that the cavities reach into the inner 1/3 of the dentin without exposure of the pulp.

Note: It is not acceptable to mix a luting agent to a heavier than luting consistency and test it as a filling material.

When preparing full crowns and to ensure acceptable proximity to the pulp (0.5-1.0mm) it is recommended to first prepare a Class V cavity, essentially serving as a guide to reach the desired proximity to the pulp, followed by completion of the crown preparation.

6.4.3.2.3 For preparation of test materials, follow the manufacturer's instructions. If the manufacturer of the test material recommends its use with a lining material or cavity treatment agent (e.g. a dentin adhesive agent), use these additional procedures as recommended by the manufacturer.

6.4.3.2.4 For each time period, restore at least seven cavities with the test material and four cavities with a negative control on the basis of a random allocation. Restore up to four cavities with a positive control for each time period.

The species selected should be the lowest required to satisfy the scientific objective at the lowest animal welfare cost. The choice of species shall be justified and documented. If monkeys, dogs or miniature pigs are used, one animal should be used for each time period. If ferrets are used, at least three animals should be used for each time period.

NOTE 1 Negative control. A quick setting zinc oxide and eugenol is an appropriate negative control providing it is placed at an acceptable distance from the pulp, i.e. >0.5mm. Any teeth with a remaining dentin thickness of <0.5mm should be excluded from the evaluation (the closer the filling to the pulp the more of an irritant the unreacted eugenol becomes). For the long-term evaluation the zinc oxide-eugenol should be protected against washing out. After a cut-back a self curing glass ionomer can provide an effective seal.

NOTE 2 In case the test material is of such a composition that a long lasting surface seal is indicated, Zinc oxide and eugenol (ZOE) is contraindicated as unreacted eugenol in the material (abundantly present after setting) will leak along the test material and reach the floor of the cavity preparation thus obscuring the true reaction of the experimental test material; a histological reaction of the eugenol will be evaluated instead. Whenever a test material needs to be protected from washing out, the following technique is recommended. After a conservative cutback of the test material by 0.5-1.0 mm, followed by etching the enamel margins, rinsing and lightly drying an adhesive bonding agent and a light cured resin composite are used.

NOTE 3 Positive control. A restorative material or technique not involving exposure of the pulp, which consistently results in moderate to severe pulpal response, is an appropriate positive control. Due to the fact that silicate cement, which was

historically used as positive control, is no longer available it is difficult to direct the clinician to another material. A “wet” mix of zinc phosphate cement is arguably the most suitable positive control. A wet mix is defined as having too little powder incorporated in the final mix. For laboratories that have a data bank on file from one and the same operator and who uses the same animal model system, a comparison with a previous test material that has reached the market may be made, providing favorable clinical data is available.

6.4.3.2.5 Random selection should be used to determine which cavities receive the test filling material, negative control material, and positive control material prior to cavity preparation. As reasonably possible, anatomically pair the control and experimental teeth, i.e., right maxillary premolar and left maxillary premolar, mandibular right premolar and maxillary right premolar, etc. By random selection, one tooth becomes the test specimen and the contralateral and opposing teeth become control specimens. Depending on the species of animal and its availability, the tooth selection may be modified.

6.4.3.2.6 The condition of the animals should be checked and recorded at least once per day post-operatively. Measures should be in place to minimize any pain or distress caused by changes in eating habits, inflammation or infection. Analgesics should be administered as required postoperatively.

6.4.3.3 Euthanasia

At the termination of the experimental period euthanize the animal with an overdose of anesthetic or by other acceptable humane methods (see ISO 10993-2 or the most recent recommendation by the AVMA Panel on Euthanasia).

6.4.3.4 Preservation of the Dental Pulp

Vascular perfusion of the tissues with fixative at the time of sacrifice provides better fixation. Perfusion euthanasia techniques will preserve most tissues but not the dental pulp. Chemical fixatives do not penetrate an intact tooth rapidly enough (within 20 minutes) to forestall autolysis. The apical third of the root must be removed after dissecting the jaws from the head. An acceptable and effective method is a high-speed hand piece and diamond or carbide bur with copious water cooling to cut the root ~4-5 mm from the apex by cutting through the bone and root or through the apical third in case the teeth are extracted. This method does not affect the coronal pulp and is indicated for indirect and direct pulp capping studies. Thorough rinsing after accessing the root and pulp tissues will remove cutting debris that may prevent the fixative to reach the pulp.

A red dot representing the pulp tissue should be visible in each root canal apex before the jaw quadrants are placed in fixative. If human teeth slated for extraction have been used the method is similar. Remove at least 3-4 from the apex, rinse and check for visibility of the pulp, which should appear as a red dot.

If the experiment aims at evaluating the apical portion perfusion euthanasia is the preferred method to achieve the best possible preservation of tissues at the apical area, however, pulpal tissue is not adequately fixed and requires accessing the pulp through bone and root at the cervical area using the above-described technique.

6.4.3.4.1 Leave the jaw blocks in the chemical fixative for at least 24 hours, replenish with fresh fixative and leave for another 24-48 hours before beginning demineralization (see 3.3.3.5 for demineralization). The amount of fixative should be 5 times the volume of the sample. After fixation, demineralize teeth in a suitable reagent and use standard techniques for paraffin imbedding.

6.4.3.4.2 Indications of autolytic changes include cytoplasmic vacuolization of the odontoblasts, reticular atrophy, smudged erythrocytes, and large, dilated empty channels resembling lymphatics (sometimes referred to as varicosities), and generalized displacement of odontoblasts into dentinal tubules. Vacuoles within the cytoplasm of odontoblasts visible with light microscopy develop so readily that by themselves they should seldom be considered of pathologic significance even in the best preserved specimens. Complete autolytic destruction of the pulp is still described in many textbooks as the classical characteristic of “reticular atrophy” that has been attributed to the effects of aging, periodontal disease, numerous types of restorative materials, operative procedures, and even to general anesthesia.⁵

6.4.3.4.3 Many types of demineralization techniques and chemicals can be used, and the most common agents are 10% formic acid, EDTA, nitric acid or formic acid-sodium citrate. Another suitable agent is Cal-X II Fixative/Decalcifier composed of Hydrochloric acid, Disodium EDTA and a fixative, which prevents loss of cellular structures (Fisher Scientific). Regardless of the technique, persons must become familiar with a technique to use it most effectively. For instance, with formic acid (using 10 times the volume of the size of the specimen) the solution should be changed every 4 to 5 days because water accumulates

as the formic acid is utilized. Also, the solution must be mechanically agitated to break up the acid-water interface around the tooth as the water accumulates about the tooth. Specimens should also be suspended in the holding vat because surfaces of teeth on the bottom of the container are not attacked by the acid.

6.4.3.4.4 As the acid solution is changed, the mesial and distal surfaces of the teeth can be trimmed. By removing excess tissue the demineralization process is speeded up. Demineralization is usually completed in 10 to 21 days depending upon the size and mineral density of the specimen. To detect the end-point of demineralization, radiography has been employed. Also teeth have been trimmed with a sharp razor blade until they cut easily, which may also indicate that over-demineralization has occurred. Careful checking on a daily basis and assessing the ease of trimming can prevent this, however.

6.4.3.4.5 Prepare 5 to 10 μm thick serial sections through each cavity in the longitudinal axis of a tooth; stain alternate slides with hematoxylin and eosin. Stain intermediate slides (adjacent to the relevant pulp lesion, preferably the one next to the section with the narrowest remaining dentin thickness), with an appropriate bacterial stain (e.g., Brown & Brenn, McKay, or Gram-Weigert stains) to estimate the number of microorganisms present and extent of microleakage. There are shortcomings associated with such staining techniques: gram-negative bacteria cannot be readily identified in most cases, and no information can be obtained about the viability or identity of these organisms. A large number of microorganisms may be lost during tissue processing, making quantification difficult. Demineralization causes substantial reduction in the number and stainability of microorganisms. The quantity of plaque or microorganisms in the margins and walls of the cavity preparation and on the floor of the preparation, as well as the number of dentin tubules invaded by microorganisms should be noted with grades of involvement ranging from 0 to 3. The percentage of specimens revealing microorganisms should be recorded.

6.4.3.5 Preparation of slides

6.4.3.5.1 After 5 ± 2 , 25 ± 5 and 70 ± 5 days, euthanize with an overdose of anaesthetic, or by applying other generally accepted substances, a sufficient number of animals to provide at least seven teeth containing test material. Examine the restorations, the teeth and their supporting tissues and record details of any abnormalities. Remove each treated tooth, together with its surrounding hard and soft tissues, and fix in a suitable fixing agent.

6.4.3.6 Assessment of dentin and dental pulp

Examine the sections without prior knowledge of whether the test sample is experimental or control. For each series of sections, record a full description of all the histological features in the dentin, pulp and periapical tissues, including any that may have arisen from the cavity preparation technique. From the serial sections, select at least five evenly spaced through the cavity for subsequent analysis of inflammation. Grade separately the inflammatory infiltrate in the superficial tissues (odontoblast layer, cell-free zone and cell-rich zone) and in the remainder (deeper tissues) of the pulp, on the scale specified in Table 6.

Table 6 — Grading scale for the pulp and dentin usage test

Grade of inflammation	Description of inflammatory changes
0	No inflammation: normally structured pulp tissue adjacent to the dentin in tubular contact with the cavity floor
1	Mild inflammation: scattered inflammatory cells within an otherwise normally structured pulp tissue adjacent to the dentin in tubular contact with the cavity floor
2	Moderate inflammation: inflammatory cells with small focal groupings within a pulp tissue still containing structurally normal areas adjacent to the dentin in tubular contact with the cavity floor
3	Severe inflammation: extensive inflammatory cell infiltration, with loss of normal structure, in the pulp tissue adjacent to the dentin in tubular contact with the cavity floor
4	Abscess formation or extended inflammatory cell infiltration not limited only to the pulp tissue adjacent to the dentin in tubular contact with the cavity floor

For each section graded, record the minimum remaining dentin thickness by measuring both at right angles from the cavity floor to the pulp-(pre)dentin interface and by measuring along the course of the dentinal tubules. In the latter case, when the plane of sections is not exactly the same as that of the dentinal tubules, so that each tubule in the area of interest does not run the full distance from the cavity floor to the pulp-(pre-) dentinal interface, take the measurement along the line of the general direction of the dentinal tubules. Calculate an index of inflammatory response at both sites, at each time interval, by summing the individual grades and by dividing by the total number of observations.

Present the data separately for cavities filled with the test material, including the lining material or cavity treatment agent if recommended by the manufacturer, with the negative control and with the positive control. For cavities filled with the positive control, data may be obtained from previous studies where the test conditions were identical. In addition, record the number of cavities containing bacteria on the cavity floor or wall at each time interval for the test material and controls. An index of inflammatory response at each time interval is thus provided for each material, based on the above scale, and which is qualified by presentation of the range of minimum remaining dentin thickness measured and the amount of bacterial microleakage observed.

6.4.3.7 Odontoblast cell survival analysis (optional)

For histomorphometric analysis of odontoblast survival, select at least five sections, evenly spaced along the cavity floor and stained with hemotoxylin and eosin, and examine them at a magnification which permits identification of discrete cells and provides a field of view encompassing all of the pulp-(pre-)dentin interface beneath the cavity. Using an ocular graticule (reticule), count the number of morphologically intact odontoblasts per unit length of pre-dentin surface along the entire length of the pulp-(pre-)dentin interface beneath the cavity. The interface is defined as that in which the dentinal tubules are in communication with the floor of the cavity, as in Figure 1.

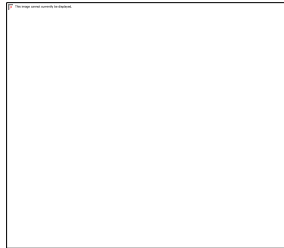

Key

- 1 cavity
- 2 dentinal tubules
- 3 pulp-(pre-)dentin interface area for counting of odontoblasts

Figure 1 — Pulp-(pre-)dentin interface area for counting of odontoblasts

Make odontoblast cell counts per unit length of the pulp-(pre-)dentin interface area beneath the cavity for each of the five sections from each test sample and derive the mean cell count for that cavity. Then derive mean cell counts for all the test, T , and the negative control, NC , cavities. The cell death in % is calculated from Equation (1):

$$CD = \left(\frac{NC - T}{NC} \right) \times 100 \quad (1)$$

where

CD is the cell death as a percentage;

NC is the cell count in the negative control cavity;

T is the cell count for the test material cavity.

Grade the odontoblast cell death on the scale as specified in Table 7.

Table 7 — Grading of odontoblast cell death

Scale	Odontoblast death
0	None
1	< 25 % cell death
2	25 % to 50 % cell death
3	> 50 % to 75 % cell death
4	> 75 % cell death

For each section graded, record the minimum remaining dentin thickness as described above. An index of odontoblast survival is thus provided for each material, based on the above scale, and which is qualified by presentation of the range of minimum remaining dentin thickness measured for the cavities in that material group. Present data separately for cavities filled with the test material, including the lining material or cavity treatment agent if recommended by the manufacturer, and for cavities used as positive controls. Express the data for the positive controls as a percentage of the negative control as per the test cavities above. Where appropriate, the data for the positive control may be obtained from a previous study, in which the test conditions were identical to those of the present study.

6.4.4 Assessment of results

In assessing the test results, take into account all information gathered in the test, particularly any differences in results between the experimental and control groups. Record the results of the assessment in the test report.

6.4.4.1 Statistical analysis

Remaining Dentin Thickness (RDT). This data is recorded in mm and should be analyzed using a parametric analysis. When results are reported in degrees (non-parametric data) in categories such as those that are listed above under Histologic Characteristics, a non-parametric test should be used.

6.4.5 Test report

Submit the results in a test report that includes a complete record of all procedures followed, results obtained and any other data necessary for the assessment of results. Include details of the preparation and methods of application of the test material, together with the lot number of the material.

6.5 Pulp capping test

6.5.1 Objective

The test is designed to assess the biocompatibility of pulp capping materials with the dental pulp. Include in the assessment methodology procedures necessary for the proposed clinical use of the material.

NOTE 1 With a few modifications, this test can be used for pulpotomy testing.

NOTE 2 The pulp and dentin usage test and the pulp capping test may be performed at the same time in the same animals using different teeth.

6.5.2 Animals and animal welfare

Conduct animal welfare in accordance with 6.4.2.

Use a minimum of two non-rodent mammals of one species, as described in 6.4.2.

6.5.3 Test procedure

6.5.3.1 Preparation of animals

Select sufficient animals to provide at least ten teeth containing test material and 5 control teeth for each time period.

Anesthetize the animals and carry out the procedure described in 6.5.3.2.

6.5.3.2 Treatment of teeth

6.5.3.2.1 Remove all calculus and debris from the tooth surfaces. Place a rubber dam to isolate the teeth to be used. Clean the tooth surface and the operating field and dry. Disinfect by swabbing with 3 % (volume fraction) hydrogen peroxide followed by a disinfectant consisting of povidone-iodine or chlorhexidine. Prepare the required number of Class V buccal or labial cavities using sharp burs under an adequate air-water spray. The preparations should be bordered by enamel but extend into the mesial and distal surfaces of the tooth and into the inner one-third of the dentin. In the center of the cavity, carefully make a pulpal exposure of approximately 0,5 mm to 1,0 mm diameter under a spray of sterile saline solution [0,9 % (mass fraction)] without plunging the bur into the pulp tissue. The approximate diameter of the exposure should be measured in tenths of a millimetre. The diameter of the exposure can be estimated from the known diameter of the bur. Thoroughly irrigate the exposure site with sterile saline solution until haemostasis is achieved. Dry with sterile cotton pellets.

NOTE If animals have marked gingival inflammation, it might be necessary to carry out a calculus and debris removal a few days before cavity preparation and even repeatedly until gingival inflammation is controlled.

6.5.3.2.2 For the preparation of test materials, follow the manufacturer's instructions. If the manufacturer recommends other irrigating solutions or reagents for the termination of hemorrhage or specific pre-treatment of the pulp wound, follow the manufacturer's instructions.

6.5.3.2.3 For each time period fill at least ten cavities with the test material and five with a suitable reference material on the basis of a random allocation. Mix the capping and control materials on a slab (pad), avoiding microbial contamination. Apply the materials to the pulp wound without pressure. Restore the cavity with either a polyacid-modified resin-based composite or a resin-modified glass ionomer cement. This should be followed by an adhesively bonded resin-based composite restoration.

The species selected should be the lowest required to satisfy the scientific objective at the lowest animal welfare cost. The choice of species shall be justified and documented. If monkeys, dogs or miniature pigs are used, at least two animals should be used for each time period. If ferrets are used, at least four animals should be used for each time period, as only the canines are suitable.

NOTE 1 A mineral trioxide aggregate (MTA) is an appropriate reference control. To prevent washing out of the MTA after placement as it is a non-setting material apply a light curing RMGI material to the MTA and 0.5-1mm surrounding dentin. Restore to final contour using an acid etch/dentin bonding agent/resin composite.

6.5.3.2.4 Observe and manage the animals as described in 6.4.3.2.4.

6.5.3.3 Preparation of slides

6.5.3.3.1 After (25 ± 5) days and (70 ± 5) days, euthanize with an overdose of anaesthetic, or by applying other generally accepted substances. a sufficient number of animals to provide at least ten teeth containing test material. Examine the restorations, the teeth and their supporting tissues and record details of any abnormalities. Remove each treated tooth, together with its surrounding hard and soft tissues, in a single block and fix in a suitable fixing agent.

NOTE Vascular perfusion of the tissues with fixative at the time of sacrifice prior to their removal provides better fixation (See 6.4.3.4).

6.5.3.3.2 After fixation, take a radiograph of each tissue block to determine whether radiographic changes have occurred. Prepare sections for examination as in 6.4.3.3.2.

6.5.3.4 Assessment of dental pulp

Examine the sections, describe the histological features, grade the inflammatory infiltrate and calculate the index of inflammatory response according to the protocol described in 6.4.3.4. As the superficial pulp tissue will have been destroyed in creating the pulpal exposure, prepare a single grading of the inflammatory infiltrate, using the scale specified in Table 8.

Table 8 — Grading scale for the pulp capping test

Grade of inflammation	Description of inflammatory changes
0	No inflammation
1	Mild inflammation: scattered inflammatory cells in the pulp tissue adjacent to the pulpal exposure
2	Moderate inflammation: inflammatory cells with small focal groupings in the pulp tissue adjacent to the pulpal exposure
3	Severe inflammation: extensive inflammatory cell infiltration in the pulp tissue adjacent to the pulpal exposure
4	Abscess formation or extended inflammatory cell infiltration not limited only to the pulp tissue adjacent to the pulpal exposure

In addition, a full description of the extent, distribution and the nature of any dentin bridge shall be provided, paying particular attention to the presence of tunnel defects and cellular inclusions which may interfere with the effectiveness of the bridge as a barrier. Grade the degree of bridging of the exposure by tertiary dentin on a scale of none, partial or complete. Guidance on the interpretation of the histological features of dentin bridging is provided in the note below.

NOTE The extent and distribution of any dentin bridge should be considered in terms of whether it completely bridges the pulpal exposure site, its depth or thickness and also, its distribution in relation to the site of exposure. An incomplete bridge does not provide effective protection to the exposed pulp. While an adequate depth of bridge is required for effective pulpal protection, uncontrolled reparative dentinogenesis for bridge formation may cause occlusion of the pulp chamber and compromise the vitality of the pulp. Widespread reparative dentinogenesis beyond the local confines of the dentin bridge and its tubular communication with the material may be suggestive of a cellular response to injury (e.g. surgical injury) beyond the direct response to the material. The regularity of the tubular structure in the dentin bridge can be informative of the degree of dysplasia during its formation with absence or the presence of few tubules suggesting more dysplastic tissue formation. The presence of tunnel defects and cellular inclusions in the dentin bridge are also indicative of dysplastic tissue formation and may impact on the permeability and degree of seal that the bridge can provide.

6.5.4 Assessment of results

Assess the results as in 6.4.4, including statistical analysis of results.

6.5.5 Test report

Submit the results in a test report as in 6.4.5.

6.6 Endodontic usage test

6.6.1 Objective

The test is designed to assess the biocompatibility of endodontic materials with the remaining apical pulp tissues (stumps) and the periapical tissues. In the assessment, include procedures necessary for the proposed clinical use of the material.

NOTE The endodontic usage test should be used for bioactive endodontic materials, e.g. materials claiming to stimulate apical hard tissue formation, intended for either orthograde or retrograde application.

6.6.2 Animals and animal welfare

Animal welfare shall be in accordance with 6.4.2.

Use a minimum of four non-rodent mammals of one species as described in 6.4.2, of such an age that their dentition contains intact permanent teeth with closed (mature) apices; the use of incisors, canines and premolars is preferred. The use of premolars is optional if two roots are present.

6.6.3 Test procedure

6.6.3.1 Preparation of animals

Select sufficient animals to provide at least ten teeth containing test material for each time period.

NOTE In some breeds of dog, the morphology of the apical part of the root canals may make root preparation difficult.

Anesthetize the animals and carry out the procedure described in 6.6.3.2.

6.6.3.2 Treatment of teeth

6.6.3.2.1 Take radiographs showing the periapical region of all teeth to be filled. Clean and isolate the teeth with a rubber dam as described in 6.4.3.2.1.

NOTE If animals have marked gingival inflammation, it might be necessary to carry out calculus and debris removal a few days before cavity preparation, and even repeatedly until gingival inflammation is under control.

Prepare the required number of teeth for placement of root canal fillings. Make an appropriate opening in the pulp chamber using sharp burs, under aseptic conditions. Debride the exposed pulp with saline solution [0,9 % (mass fraction)] and dry with sterile cotton pellets. Use a new sterile root canal file or a barbed broach to sever the pulp ($1,0 \pm 0,5$) mm from the apical foramen, using the radiographs as a guide during instrumentation. Irrigate the root canal repeatedly with sodium hypochlorite solution (recommended concentrations range from 1,0 % to 5,25 % (mass fraction) followed by sterile 0,9 % (mass fraction) saline solution.

Enlarge the root canal using progressively larger, sterile, root canal files, calibrated in length to the level at which the pulp has been severed, until it is a suitable size for filling. Make every effort to eliminate dentinal chips from the root canal, which could block the tooth apex and prevent the endodontic material from contacting the apical tissue. Following completion of the instrumentation, flush the root canal with sodium hypochlorite solution (recommended concentrations range from 1,0% to 5,25% (mass fraction)) followed by sterile 0,9% (mass fraction) saline solution and dry with sterile cotton pellets and large, blunted, sterile paper points without contacting the apical pulpal stump.

6.6.3.2.2 For the preparation of test materials, follow the manufacturer's instructions. If the manufacturer recommends tooth preparation procedures different from those described above, follow the manufacturer's instructions.

6.6.3.2.3 For each time period, on the basis of a random allocation, fill at least ten teeth with the test material and at least five with a suitable reference material. Mix the endodontic and reference materials on a slab (pad), avoiding microbial contamination. Fill the root canal with either the test or reference material, using gutta percha at the point of pulp severance. Obturate the access cavity with a reinforced ZOE cement, covered by either a polycarboxylate cement or a conventional (self-cure) glass-ionomer cement or an acid-etch retained resin-based composite. Take radiographs showing the periapical region of all teeth that have been filled.

If monkeys, dogs or miniature pigs are used, at least two animals should be used for each time period. If ferrets are used, at least four animals should be used for each time period as only the canines are suitable.

If a resin-based composite is used, a thin layer of either conventional (self-cure) glass-ionomer cement or polycarboxylate cement should be placed initially over the ZOE. Placing a resin-based composite in direct contact with ZOE cement may result in inhibition of polymerization of the resin-based composite.

NOTE ZOE cement, either alone or with other additives as in Grossman's sealer, is an appropriate reference material.

6.6.3.2.4 Observe and manage the animals as in 6.4.3.2.4.

6.6.3.3 Preparation of slides

6.6.3.3.1 After (28±3) days and (90±5) days, euthanize with an overdose of anaesthetic, or by applying other generally accepted substances, a sufficient number of animals to provide at least ten teeth containing test material. Examine the restorations, the teeth and supporting tissues and record details of any abnormalities. Remove each treated tooth, together with its surrounding hard and soft tissues in a single block, and fix in a suitable fixing agent.

NOTE Vascular perfusion of the tissues with fixative at the time of sacrifice prior to their removal provides better fixation.

6.6.3.3.2 After fixation, take a radiograph of each tissue block to determine whether radiographic changes have occurred. Prepare sections for examination as in 6.4.3.3.2, parallel to the long axis of the tooth through the root canal and its ramifications, showing the material/pulp tissue interface and the adjacent periapical tissues.

6.6.3.4 Assessment of tissues

Examine the sections without prior knowledge of whether the test sample is experimental or control. For each series of sections, record a full description of all the histological features in the pulp, periapical tissues, dentin and cementum in the apical part of the tooth. For each test sample, grade the tissue changes according to the scale specified in Table 9. Examples of the histological features to be considered are provided in the note below.

Table 9 — Grading scale for the endodontic usage test

Scale	Observation
0	No inflammation
1	Mild inflammation: test samples display a scattering of inflammatory cells, predominately chronic inflammatory cells, and the structural characteristics of residual pulp are still identifiable
2	Moderate inflammation: test samples display focal accumulations of inflammatory cells but no tissue necrosis, and some disruption of the structural characteristics of the residual pulp and periapical tissues
3	Severe inflammation: extensive replacement of the residual pulp or periapical tissues by an inflammatory cell infiltrate
4	Abscess formation

NOTE Examples of the histological features to be recorded include the following.

- a. An assessment to determine whether the root canal filling is short, flush or extruded: correlate this observation with the presence of inflammation, root resorption and bone reaction.
- b. Extrusion of root canal sealer (cement): determine whether root canal sealer has been extruded through the apex into the surrounding periodontal space and bone tissues. Although most likely to be observed at the 28 d interval, the long-term period should not be excluded from this assessment.
- c. The presence of necrotic apical tissue.
- d. The quality of the adaptation of the root canal filling material grading as good, fair or poor: good adaptation means that the filling material is well adapted to the root walls on not just one section but on serial sections, without showing voids. Fair is graded when some sections show voids or areas where the filling material is not well adapted to the root. A poor adaptation is recorded when the filling material is not flush with the root wall or when numerous voids are present.
- e. Further specification of the inflammation outlined above (and graded from 0-4) as to the type of inflammatory cells that are present: list the predominant type of cell and recognize that the acute cells (leukocytes) appear early while mononucleated cells (lymphocytes, monocytes, macrophages and multinucleated giant cells) appear later. Classify the inflammatory reactions as acute (A), chronic (C) or mixed (M).

- f. Root resorption (present or absent).
- g. The reaction of the apical bone graded as normal, inflamed (grade the inflammation), and a determination whether there is a granuloma present and whether the bone shows signs of resorption.
- h. Grade of hyperaemia on a scale from 0 to 3.

6.6.4 Assessment of results

Assess the results as in 6.4.4, including statistical analyses.

6.6.5 Test report

Submit the results in a test report as in 6.4.5.

Annex A
(informative)

**Types of test to be considered for evaluation of biocompatibility of
medical devices used in dentistry**

Table A.1 — Types of test to be considered for evaluation of biocompatibility of medical devices used in dentistry

Nature of body contact	Contact duration A – Limited (u 24h) B – Prolonged (24 h - 30 d) C – Permanent (> 30 d)	Group I			Group II						Group III		
		Cytotoxicity tests ISO 7405, 6.2 and 6.3	Cytotoxicity tests ISO 10993-5	Cytotoxicity tests ISO 7405, Annex B	Delayed-type hypersensitivity ISO 10993-10	Irritation or intra-cutaneous reactivity ISO 10993-10	Acute systemic toxicity ISO 10993-11	Subchronic (subacute) systemic toxicity ISO 10993-11	Genotoxicity ISO 10993-3	Implantation ISO 10993-6	Pulp and dentin usage test ISO 7405, 6.4	Pulp capping test ISO 7405, 6.5	Endodontic usage test ISO 7405, 6.6
Surface device	A	X	X		X	X							
	B	X	X		X	X	O	O					
	C	X	X		X	X	O	X	X				
External communicating device	A	X	X	X	X	X	O				X		
	B	X	X	X	X	X	X	X	X	X	X		
	C	X	X	X	X	X	X	X	X	X	X		
Tissue/ bone Implant device	A	X	X		X	X	O					X	X
	B	X	X		X	X	X	X	X	X		X	X
	C	X	X		X	X	X	X	X	X		X	X
NOTE 1	X indicates test shall be considered for use; O These additional evaluation tests should be addressed in the submission, either by inclusion of the testing or a rationale for its omission.												
NOTE 2	This table is a framework for the development of an assessment program and is not a checklist.												

Annex B (informative)

Dentin barrier cytotoxicity test

B.1 Objective

This part of the ANSI/ADA Standard 41 describes the Dentin Barrier Test to be used either by itself or in conjunction with other cytotoxicity, immunogenicity, mutagenicity, and molecular tests.

NOTE -- The term medical device corresponds to the definition given in ISO 10993-1 and covers medical and dental materials and devices.

These methods are designed to demonstrate a change in concentration(s) of either identified components of dental materials or extracts of polymerized or set materials as used in their final form, when placed on one side of dentin and allowed to diffuse to the opposite side. This method is intended as an *in vitro* simulation of filtration and diffusion of materials from a dental cavity preparation to the dental pulp.

To measure movement of materials across a "dentin barrier," solid polymerized or set materials can be used as they would be used in practice, or constituents of these materials can be employed. To measure concentrations of constituents of filtrates or diffusates, radioisotope-labeled solutes can be used, or the solute of interest can be measured by means of colorimetry, spectrophotometry, chromatography or other methods.

B.2 DEFINITIONS

- B.2.1** In vitro pulp chamber: This is a device that holds a thin slice of human molar dentin between two chambers and allows fluid and molecules to filter or to diffuse across the "dentin barrier."
- B.2.2** Hydraulic conductance: The active movement or filtration of fluid and its constituents through a barrier such as dentin by means of a pressure gradient.
- B.2.3** Diffusion: The establishment of passive movement of solutes (solublized constituents) by means of a diffusion gradient through the "dentin barrier."

Apparatus and materials

B.1.1 Cells

An established cell line which is readily available, e.g. from the American Type Culture Collection (ATCC), or, alternatively, clonal SV 40 large T-antigen-transfected cells, e.g. derived from calf dental papilla, may be used. They are maintained in growth medium in a humidified atmosphere at (37 ± 2) °C and 5% CO₂. Other established cell lines with odontoblast-like properties or other properties that are relevant to the physiology of the dental pulpal tissues can also be used.

B.1.2 Culture medium

Medium specified for the selected cell line as given by ATCC or equivalent.

NOTE For guidance, see <http://www.atcc.org>. The growth medium for SV 40 large T-antigen-transfected cells consists of MEM α supplemented with 20 % foetal bovine serum (FBS), 150 IU/ml penicillin, 150 µg/ml streptomycin, 0,125 µg/ml amphotericin B and 0,1 mg/ml geneticin.

B.1.3 Reagents

B.1.3.1 3-(4,5-dimethylthiazol-2-yl)-2,5-diphenyltetrazolium bromide (MTT).

B.1.3.2 Antibiotics/antifungal, penicillin, streptomycin, amphotericin B and geneticin only for clonal SV40 transfected cells.

B.1.4 Equipment

B.1.4.1 Cell culture plate inserts, e.g. Millicell⁵⁾.

B.1.4.2 6-well and 24-well culture plates.

B.1.4.3 8 mm diameter polyamide meshes, e.g. Sefar⁶⁾, mesh width 150 µm.

B.1.4.4 Split chamber perfusion device.

In the following text, two perfusion chambers are described, both of which are suitable.

The first split chamber perfusion device, Minucells⁷⁾, (Figure B.1) consists of a perfusion chamber made of polycarbonate with a base of 40 mm × 40 mm and a height of 35 mm. The pulpal part of the device is connected on one side to a bottle with culture medium supply and on the other to a peristaltic pump and a bottle for waste medium. Within the test apparatus, the two chambers are separated by a dentin slice, held in place by a steel holder (Figure B.2).

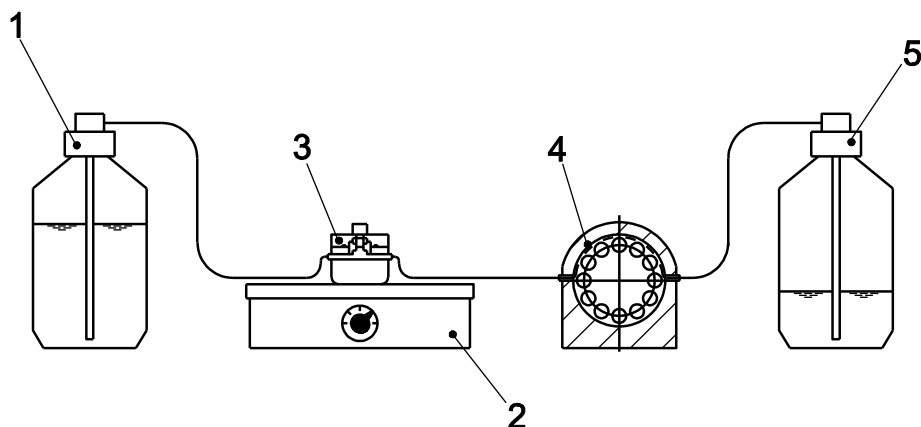

Key

- 1 supply of culture medium
- 2 hotplate
- 3 perfusion chamber
- 4 pump
- 5 waste bottle

Figure B.1 — Experimental set-up for the dentin barrier cytotoxicity test

5) Millicell is the trade name of a product supplied by Millipore, Billerica, MA, USA. This information is given for the convenience of the users of this International Standard and does not constitute an endorsement of the product named. Equivalent products may be used if they can be shown to lead to the same result.

6) Sefar is the trade name of a product supplied by Sefar, Wasserburg/Inn, Germany. This information is given for the convenience of the users of this International Standard and does not constitute an endorsement of the product named. Equivalent products may be used if they can be shown to lead to the same result.

7) Minucells is the trade name of a product supplied by Minucells & Minutissue GmbH, Bad Abbach, Germany. This information is given for the convenience of the users of this International Standard and does not constitute an endorsement of the product named. Equivalent products may be used if they can be shown to lead to the same result.

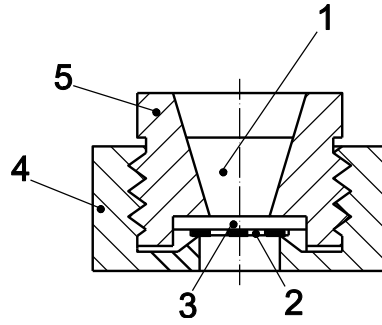

Key

- 1 test material
- 2 mesh with cells
- 3 dentin slice
- 4 steel ring
- 5 steel insert

Figure B.2 — Stainless steel holder to fixate the dentin slice and the cell culture in the test apparatus

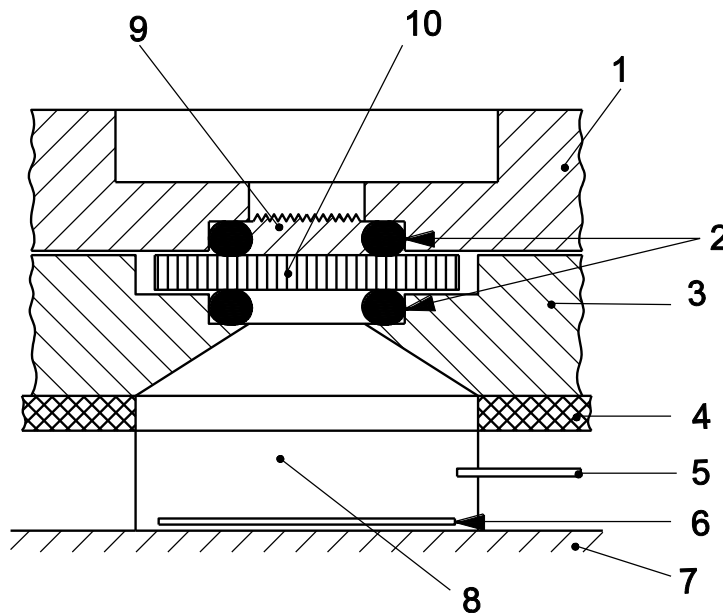

Key

- 1 top part
- 2 rubber O-ring
- 3 middle part
- 4 elastomer sheet
- 5 inlet – outlet
- 6 glass coverslip
- 7 bottom
- 8 culture medium
- 9 test material
- 10 dentin slice held in place by rubber O-rings

Figure B.3 — ADA perfusion chamber

The second split chamber device, the American Dental Association (ADA) perfusion chamber⁸⁾ (Figure B.3), consists of translucent walls fabricated from either Delrin⁹⁾ or Lexan¹⁰⁾, both of which are non-toxic. The inlet and outlet valves are non-toxic stainless steel needle ports. The small O-rings are of red silicone (15,9 mm outer diameter, 12,42 mm inner diameter). The 6 mm inner diameter of the smaller O-ring creates a surface diffusion area of 28 mm². The chamber area holds 0,5 ml of fluid. This area may be reduced by filling the chamber from the bottom with a non-toxic polyvinylsiloxane impression material (e.g. Reprosil¹¹⁾), so that there is less than 100 µl within the chamber.

B.1.4.5 Microplate reader, 96-well plates, wavelength 540 nm, or any other adequate photometer.

B.1.4.6 Dentin slices, from human or bovine dentin.

NOTE If non-human dentin is used, determine the permeability of the slices prior to use to confirm that it is similar to that of human dentin at a comparable level to the pulpal-dentin interface. Use a capillary system [e.g. Flowdec¹²⁾] for this purpose.

B.2 Test procedure

B.2.1 Cell culture preparation

B.2.1.1 Three-dimensional cell cultures

Three dimensional cell cultures are recommended to be used together with the Minucells perfusion chamber. Incubate polyamide meshes in 0.1 mol/l acetic acid for 30 min, wash three times with demineralized water, air-dry, coat with fibronectin (0.03 mg/ml) and air-dry under sterile conditions. Place a cell culture insert into each well of a 6-well plate together with 1.25 ml of culture medium. Place the meshes on the inserts and seed with 20 µl cell suspension at 4×10⁶ cells/ml. After 48 h incubation at (37 ± 2) °C and under 5% CO₂ at a relative humidity of (90 ± 10) %, transfer the meshes to 24-well plates and incubate for (14 ± 2) d. Change the culture medium three times a week and transfer the meshes to a new 24-well plate at the end of the first week.

B.2.1.2 Monolayer cultures

Monolayer cultures are recommended to be used together with the ADA perfusion chamber. Apply methods described in ISO 10993-5 using an established cell line which is readily available, e.g. from the American Type Culture Collection (ATCC).

8) ADA perfusion chamber is the trade name of a product supplied by Biomedical Engineering, Medical College of Georgia, Augusta, GA 30912, USA, #NT-8214A. This information is given for the convenience of the users of this standard and does not constitute an endorsement of the product named. Equivalent products may be used if they can be shown to lead to the same result.

9) Delrin is the trade name of a product from the material class polyacetal, supplied by DuPont. This information is given for the convenience of the users of this standard and does not constitute an endorsement of the product named. Equivalent products may be used if they can be shown to lead to the same result.

10) Lexan is the trade name of a product from the material class polycarbonate, supplied by General Electric Plastics. This information is given for the convenience of the users of this standard and does not constitute an endorsement of the product named. Equivalent products may be used if they can be shown to lead to the same result.

11) Reprosil is the trade name of a product from the material class of hydrophobic non-toxic polyvinylsiloxane impression material supplied by Dentsply International, York PA, USA. This information is given for the convenience of the users of this standard and does not constitute an endorsement of the product named. Equivalent products may be used if they can be shown to lead to the same result.

12) Flowdec is the trade name of a product supplied by DeMarco Engineering, Geneva, Switzerland. This information is given for the convenience of the users of this standard and does not constitute an endorsement of the product named. Equivalent products may be used if they can be shown to lead to the same result.

B.2.2 Preparation of dentin slices

B.2.2.1 Human origin

Select non-carious, freshly extracted molar teeth, remove debris and attached soft tissues with hand instruments and soak in 70% ethanol for at least 15 min. Prepare dentin slices by sectioning the teeth at right angles to their long axes through the widest part of their crowns, below the occlusal enamel and above the occlusal limits of the pulp chambers.

B.2.2.2 Bovine origin

Select intact teeth showing no excessive signs of abrasion, from among the median four lower incisors of 3- to 7-year-old slaughterhouse animals. Extract the teeth, remove debris and attached soft tissue using hand instruments and store in 0,5 % chloramine or other similar agents until used. Section the teeth along their long axes as close as possible to the pulp chamber. Use slices near the cervical part of the tooth for the test.

B.2.2.3 Treatment of dentin slices

Etch the intended "pulpal" aspect of the dentin slice with 50 % citric acid for 30 s, wash thoroughly and sterilize either by autoclaving (121 °C; 9.6 MPa; 25 min) in 0.9 % sodium chloride, or by soaking in 70 % ethanol for 15 min followed by thorough rinsing in demineralized water. Dentin slices may be stored in 0.9 % sodium chloride solution at (4 ± 2) °C up to three weeks. Confirm the sterility of the dentin slices by microbiological culture of a test sample from each batch before use.

NOTE The thickness of the dentin slice can vary according to the depth of the clinical cavity the test is designed to simulate. A dentin slice of (500 ± 50) µm thickness represents the amount of dentin remaining beneath a clinical cavity of medium depth. Thinner slices may be used to represent the situation in deeper clinical cavities.

Dentin slices may be stored in 0.9 % NaCl until use.

B.2.2.4 Perfusion assembly

B.2.2.4.1 Minucells device

Place the mesh with cells in the test apparatus and insert the dentin slice, held in place by a stainless steel holder.

NOTE A suitable holder is shown in Figure B.2.

Perfuse the chambers with 0,3 ml assay medium per hour (growth medium with 6 g/l HEPES buffer) for 24 h. Stop the perfusion and introduce the test material into the upper compartment in direct contact with the "cavity" side of the dentin slice.

After a suitable time period (e.g. 24 h or 3 d), remove the mesh with the cells from the pulpal part of the chamber and place into 48-well plates containing 0,5 ml of pre-warmed MTT solution (0,5 ml in growth medium) incubate for 2 h at (37 ± 2) °C with phosphate buffered saline solution. Extract the blue formazan precipitate using 0,25 ml dimethyl sulfoxide, shaking the plates at room temperature for 30 min. Transfer 200 µl of this solution to a 96-well plate and determine the absorption spectrophotometrically at 540 nm. Express the results as a percentage of controls or as photometric readings.

Use five to ten chambers for each material and control in one test, and carry out each test at least twice.

B.2.2.4.2 Assembly of the ADA-perfusion chamber

Adjust the dentin slice in the perfusion chamber device. Fill the lower compartment with suitable cell culture medium (or another extraction vehicle) and connect it to supply and waste bottles, if necessary. Then fill in the test materials. After a given exposure time, remove the cell culture medium and use it for cytotoxicity testing in routine monolayer cultures, e.g. using DNA synthesis, mitochondrial activity (MTT assay), or stimulation of functions such as gene regulation as biological endpoints.

B.3 Controls

Use positive and negative controls for each material tested. The positive control should reduce cell viability by approximately 50 % after 24 h exposure; the negative control should have no effect on cell viability. An example for a positive control material¹³⁾ is given in Table B.1.

NOTE As a negative control, a hydrophobic non-toxic polyvinylsiloxane impression material is suitable. As a positive control, a material with the compositions listed in Table B.1 or an equivalent material can be used.

Table B.1 — Example of positive control material

Material	Weighted sample mg	Weighted sample %	Final weight %
Powder			
Glass powder	829.000	82.90	66.30
Polyacrylic acid	146.000	14.60	11.70
Diphenyliodonium chloride	25.000	2.50	2.00
Total	1 000.00	100.00	80.00
Liquid			
Camphorquinone	0.625	0.25	0.05
Ethyl-4-dimethylaminobenzoate	0.625	0.25	0.05
HEMA	187.500	75.00	15.00
Distilled water	61.250	24.50	4.90
Total	250.000	100.00	20.00

NOTE See Reference [31].

Mix the components of the powder and the liquid separately and then immediately mix both in a ratio of 1 000 mg powder and 250 mg liquid. Cure it by a standard curing unit for 40 s at 700 mW/cm² to 800 mW/cm².

B.4 Assessment of results

Discard the experiment if no statistically significant difference between the negative and positive control occurs. Data should be analyzed using a parametric test for discreet data or non-parametric test should be used when a scoring system is used for severity evaluation.

In addition to the assessment described, consult ISO 10993-5 for further information. The assessment of data derived from the Minucells device is based on a statistical comparison (non-parametric methods) of the data

13) The following raw materials are examples of suitable products available commercially. This information is given for the convenience of users of this International Standard and does not constitute an endorsement of this product.

Glass powder with grain size 30 µm ± 10 µm: Schott, order No. GM35429.

Polyacrylic acid: Sigma-Aldrich, order No. 323667.

Diphenyliodonium chloride: Sigma, order No. D209082.

Camphorquinone: Sigma, order No. 124893.

Ethyl-4-dimethylaminobenzoate: Merck, order No. 841086.

HEMA (2-hydroxyethyl-methacrylate): Merck, order No. 800588.

from the test material with those from the control materials, assuming five to ten independent cultures for each material. Assess cell damage according to Table B.2 and grade the results according to Table B.3.

Include the results of the assessment in the test report.

Table B.2 — Assessment of cell damage

Scale	Grading assessment
0	Not statistically different from negative control, but different from the positive control or inducing even less cell damage than the negative control
1	Statistically different from both, the negative and the positive control
2	Not statistically different from positive control, but different from the negative control or inducing even stronger cell damage compared to the positive control

Table B.3 — Grading of test material

Scale	Description
0	Non cytotoxic
1	Moderately cytotoxic
2	Severely cytotoxic

B.5 Test report

The test report shall include the following information:

- a. cell line used;
- b. culture medium used;
- c. details of the test material;
- d. details of the test material preparation;
- e. details of positive and negative controls;
- f. the percentage of cell viability, compared to the negative control;
- g. results of the assessment.

Annex C

(informative)

Acute toxicity testing

The classical LD₅₀ method has been found to be unnecessary and unacceptable on animal welfare grounds. The fixed dose Procedure (OECD Guideline 420^[11]), the Stepwise Procedure (OECD Guideline 423^[12]) and the “Up-and-Down” Procedure (OECD Guideline 425^[13]) have been validated for use as a regulatory acute toxicity test.

Bibliography

- [1] ISO 10993-7, *Biological evaluation of medical devices — Part 7: Ethylene oxide sterilization residuals*
- [2] ISO 10993-9, *Biological evaluation of medical devices — Part 9: Framework for identification and quantification of potential degradation products*
- [3] ISO 10993-13, *Biological evaluation of medical devices — Part 13: Identification and quantification of degradation products from polymeric medical devices*
- [4] ISO 10993-14, *Biological evaluation of medical devices — Part 14: Identification and quantification of degradation products from ceramics*
- [5] ISO 10993-15, *Biological evaluation of medical devices — Part 15: Identification and quantification of degradation products from metals and alloys*
- [6] ISO 10993-16, *Biological evaluation of medical devices — Part 16: Toxicokinetic study design for degradation products and leachables*
- [7] ISO 10993-17, *Biological evaluation of medical devices — Part 17: Establishment of allowable limits for leachable substances*
- [8] ISO 10993-18, *Biological evaluation of medical devices — Part 18: Chemical characterization of materials*
- [9] ISO/TS 22911, *Dentistry — Preclinical evaluation of dental implant systems — Animal test methods*
- [10] OECD 420: *OECD Guidelines for Testing Chemicals — Acute Oral Toxicity. Fixed Dose Procedure*, Organisation for Economic Co-operation and Development, 75775 Paris Cedex 16, France
- [11] OECD 423: *OECD Guidelines for Testing Chemicals — Acute Oral Toxicity. Acute Toxic Class Method*, Organisation for Economic Co-operation and Development, 75775 Paris Cedex 16, France
- [12] OECD 425: *OECD Guidelines for Testing Chemicals — Acute Oral Toxicity. Up-and-Down Procedure*, Organisation for Economic Co-operation and Development, 75775 Paris Cedex 16, France
- [13] BARKA, T. and ANDERSON, P.J., *Histochemistry. Theory, practice and bibliography*, Chapter XIII, Hoeber Medical Division, Harper & Row Publishers, New York, 1963
- [14] BERBERT, F.L., LEONARDO, M.R., SILVA, L.A., TANOMARU FILHO, M. and BRAMANTE, C.M., *Influence of root canal dressings and sealers on repair of apical periodontitis after endodontic treatment*, Oral Surg. Oral Med. Oral Pathol. Oral Radiol. Endod., **93**, pp. 184-189, 2002
- [15] BROWNE, R.M., *Animal tests for biocompatibility of dental materials: relevance, advantages and limitations*, J. Dent., **22**, pp. 21-24, 1994
- [16] FRANZ, A., KÖNIG, F., SKOLKA, A., SPERR, W., BAUER, P., LUCAS, T., WATTS, D.C. and SCHEDLE, A., *Cytotoxicity of resin composites as a function of interface area*, Dent. Mater., **23**, pp. 1438-1446, 2007
- [17] HANKS, C.T., DIEHL, M.L., CRAIG, R.G., MAKINEN, P.L. and PASHLEY, D.A., *Characterization of the “in vitro pulp chamber” using the cytotoxicity of phenol*, J. Oral Path., **18**, pp. 97-107, 1989
- [18] MAGLOIRE, H., JOFFRE, A. and BLEICHER, F., *An in vitro model of human dental pulp repair*. J. Dent. Res., **75**, pp. 1971-1978, 1996
- [19] MERYON, S.D., *The model cavity method incorporating dentin*, Int. Endod. J., B, pp. 79-84, 1988

- [20] MURRAY, P., HAFEZ, A.A., SMITH, A.J., WINDSOR, L.J. and COX, C.F., *Histomorphometric analysis of odontoblast-like cell numbers and dentin bridge secretory activity following pulp exposure*, Int. Endod. J., **36**, pp. 106-116, 2003
- [21] MURRAY, P.E., LUMLEY, P.J., ROSS, H.F. and SMITH, A.J., *Tooth slice organ culture for cytotoxicity assessment of dental materials*, Biomaterials, **21**, pp. 1711-1721, 2000
- [22] PAMEIJER, C.H. and STANLEY, H.R., *Pulp reaction to a dentin bonding agent*, Am. J. Dent., **8**, pp. 140-114, 1995
- [23] PASCON, E.A., LEONARDO, M.R., SAFAVI, K. and LANGELAND, K., *Tissue reaction to endodontic materials: methods, criteria, assessment, and observations*, Oral Surg. Oral Med. Oral Pathol., **72**, pp. 222-237, 1991. Erratum in: Oral Surg. Oral Med., **73**, p. 347, 1992
- [24] SCHMALZ, G., *Agar overlay method*, Int. Endod. J., **21**, pp. 59-66, 1988
- [25] SCHMALZ, G., GARHAMMER, P. and SCHWEIKL, H., *A commercially available cell culture device for dentin barrier tests*, J. Endod., **22**, pp. 249-252, 1996
- [26] SCHMALZ, G., HILLER, K.-A. and DÖRTER-ASLAN, F., *New developments in the filter test system for cytotoxicity testing*, J. Mat. Sci., Materials in Medicine, **5**, pp. 43-51, 1994
- [27] SCHMALZ, G. and SCHWEIKL, H., *Characterization of an in vitro barrier test using a standard toxicant*, J. Endod., **20**, pp. 592-594, 1994
- [28] SCHUSTER, U., SCHMALZ, G., THONEMANN, B., MENDEL, N. and METZL, C., *Cytotoxicity testing with three-dimensional cultures of transfected pulp-derived cells*, J. Endod., **27**, pp. 259-265, 2001
- [29] WENNBERG, A., HASSELGREEN, G. and TRONSTAD, L., *A method for toxicity screening of biomaterials using cells cultured on millipore filters*, J. Biomed. Mater. Res., **13**, pp. 109-120, 1979
- [31] SCHMALZ, G., HILLER, K.-A., SEIDENADER, C. AND SCHWEIKL, H., *Interlaboratory testing of a new cytotoxic reference dental restorative material*. J Dent Res., **90**, Spec Issue A, 2011 (www.dentalresearch.org), Abstract # 273, <http://iadr.confex.com/iadr/2011sandiego/webprogram/schedule/Paper146565.html>.

